

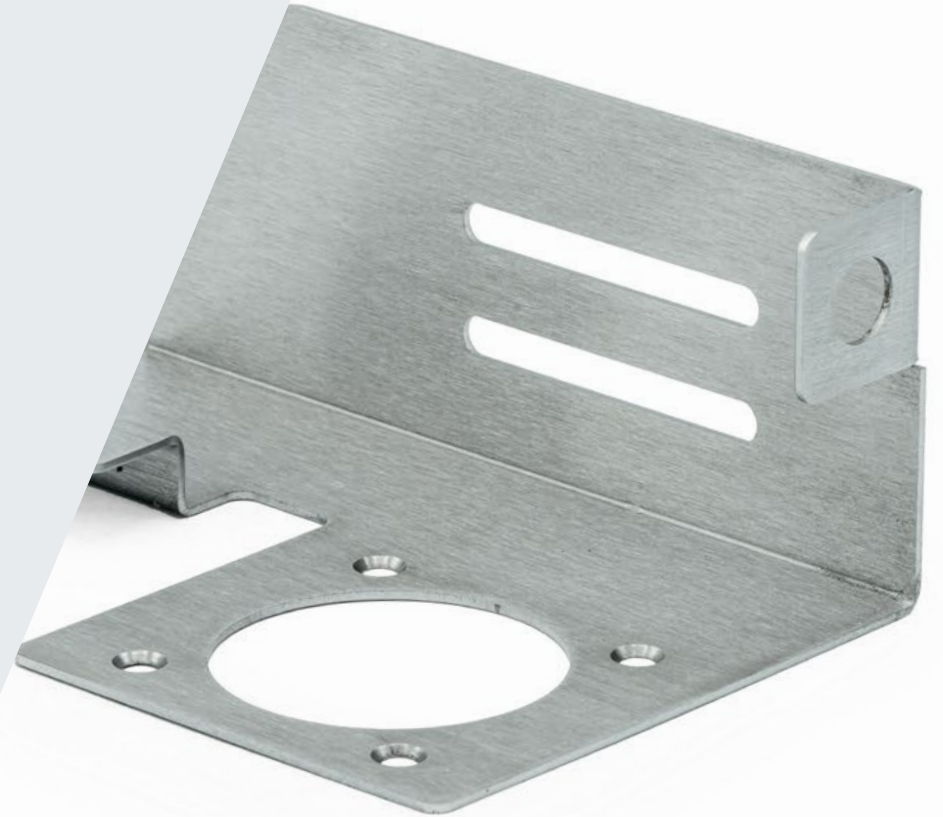

# SURFACE FINISHES

SHEET METAL



Sheet metal fabrication is one of the oldest manufacturing techniques, so it has the reputation of being rather traditional when compared to its more digitally advanced cousins, CNC machining, injection molding, and 3D printing. When you consider that people have been bending and manipulating flat sheets of various metals for millennia—including precious ones like gold, silver, and platinum—you quickly realize that sometimes the best ideas are the oldest ones. From antiquity to the present day, it's a time-tested process that yields strong, durable parts.

The great thing about modern sheet metal fabrication is the multitude of finishing options available to you to change the appearance of these humble slabs of metal. You can choose finishes that make your parts vary from industrial to polished and chic. When you do, this ancient medium comes alive and your functional parts become aesthetically pleasing, too.

This guide offers just what you need to make good choices: a visual comparison of various finishes and how each affects specific material. Specifically, we'll cover the following:

- Aluminum
- Cold-rolled steel
- Stainless steel
- Galvanized/galvannealed steel

Each has been treated to either an orbital or standard-grain finish in both Protolabs Standard or Protolabs Cosmetic quality. In the case of galvanized/galvannealed steel, the mill edge is broken and the cosmetic level is Standard. You can compare unfinished parts with finished parts, so you get an apples-to-apples comparison.

Ready? Here we go!



**FINISH**

Straight Grain

**APPEARANCE  
GRADE**

Standard

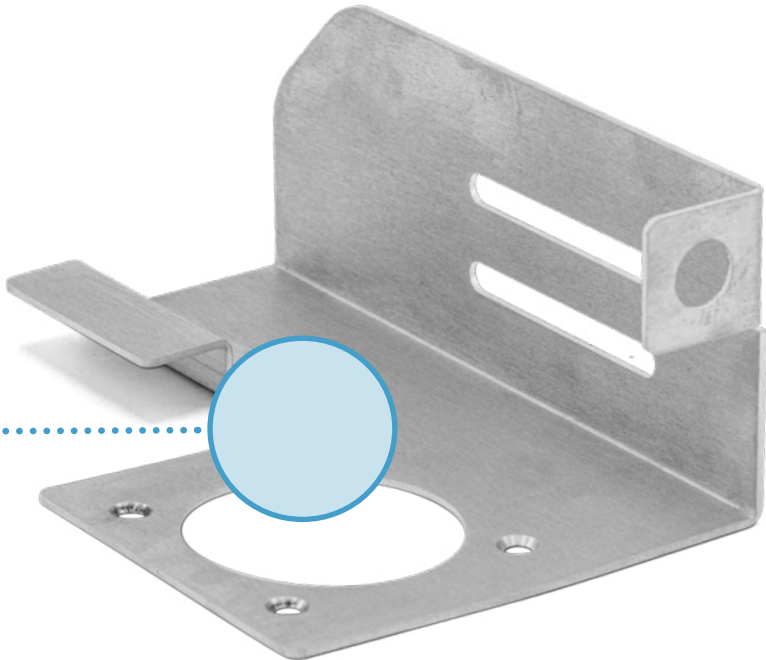
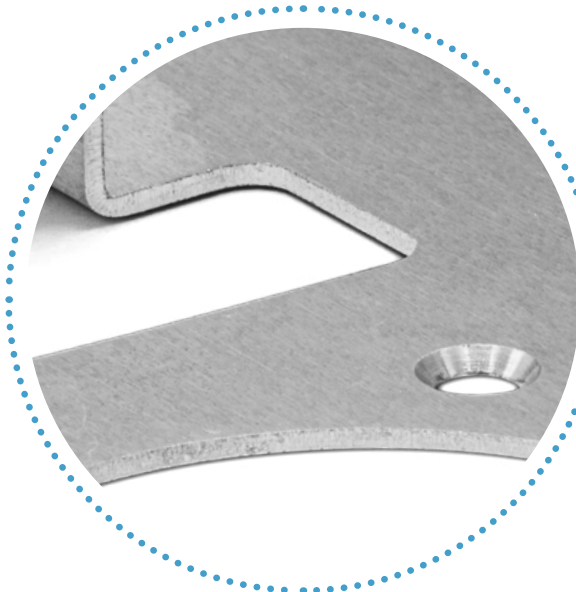

**FINISH**

Straight Grain

**APPEARANCE  
GRADE**

Cosmetic

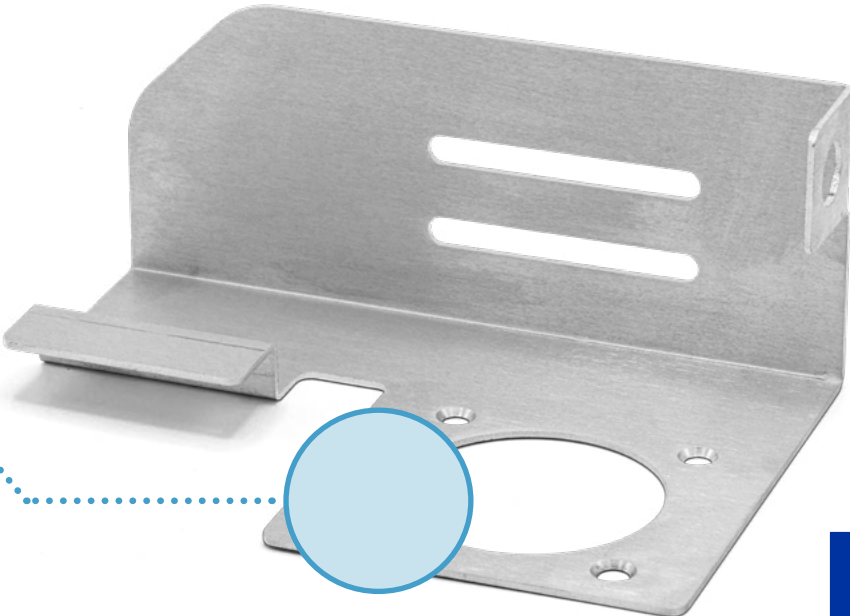
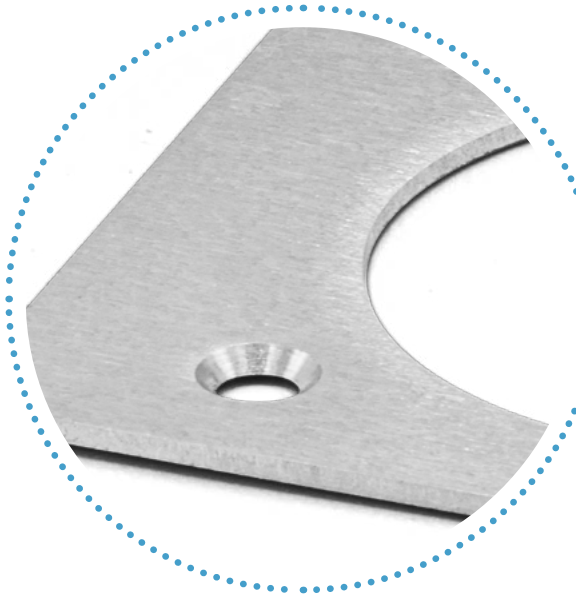

**FINISH**

Orbital

**APPEARANCE**

**GRADE**

Standard

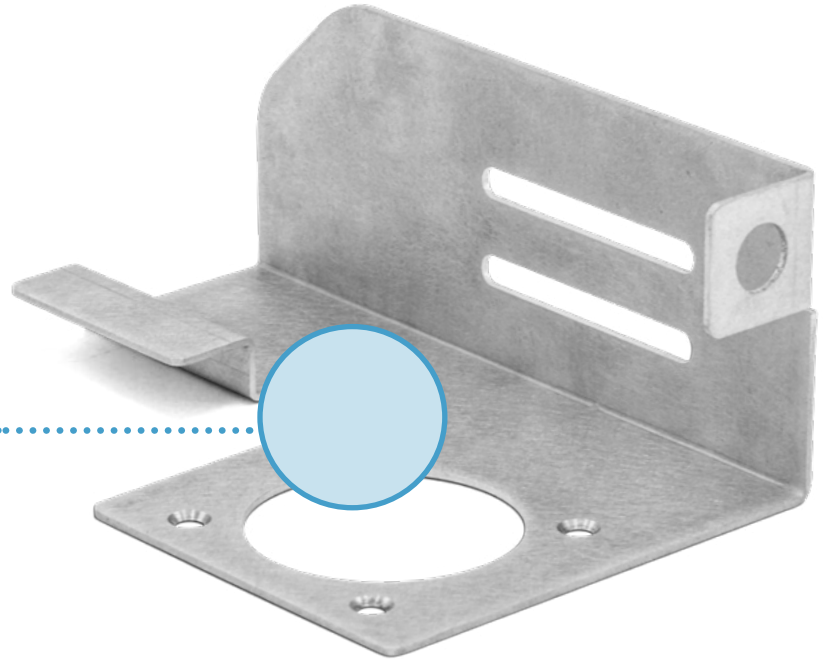
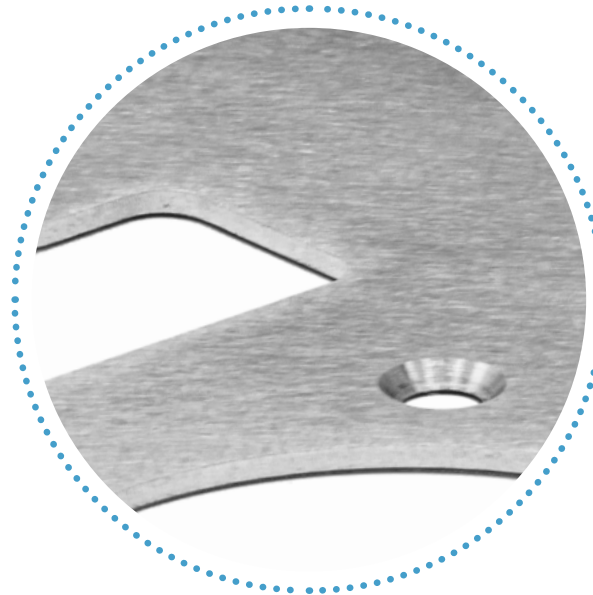

**FINISH**

Orbital

**APPEARANCE**

**GRADE**

Cosmetic

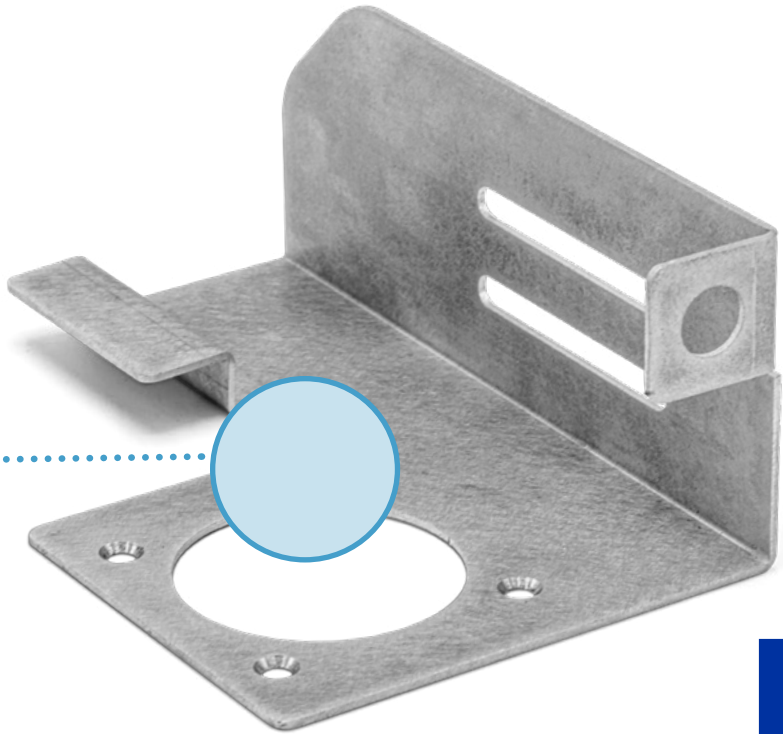
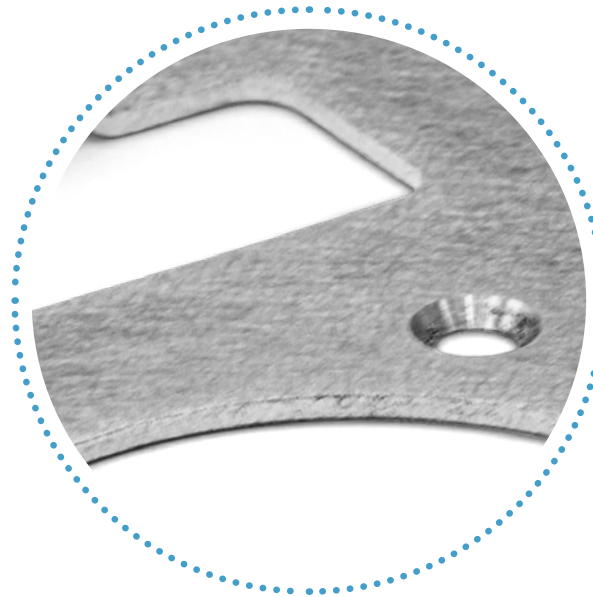

**FINISH**

Straight Grain

**APPEARANCE  
GRADE**

Standard

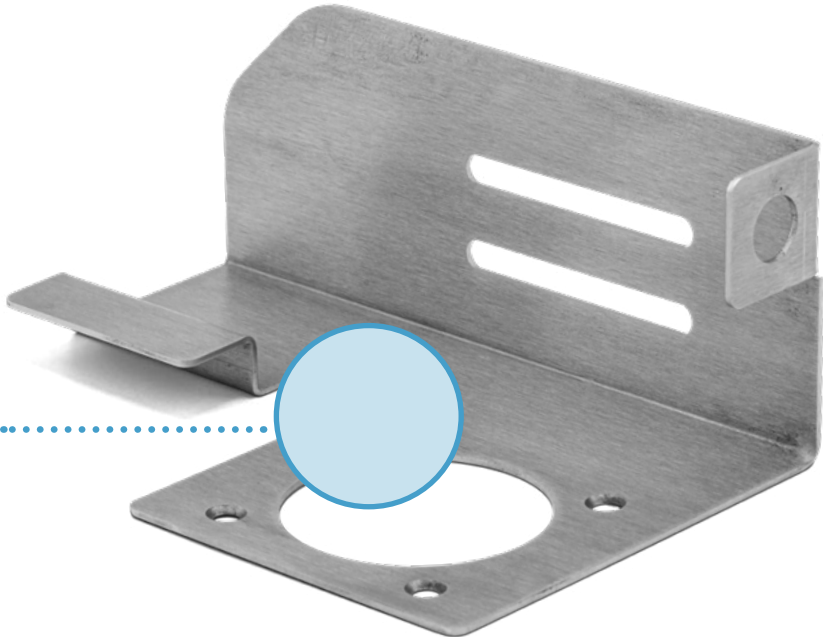
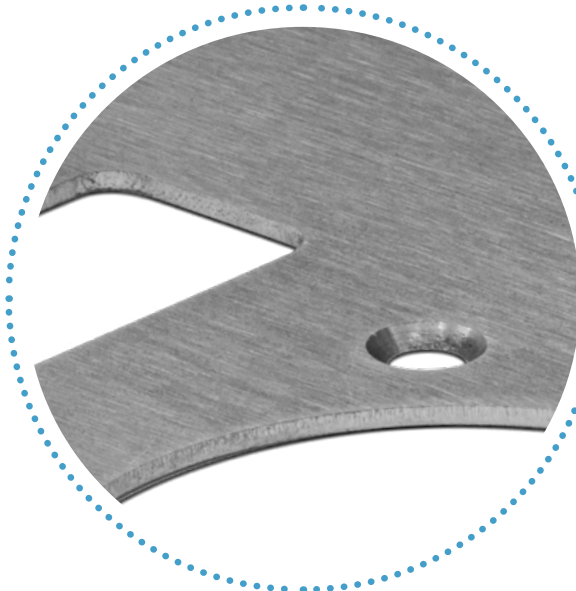

**FINISH**

Straight Grain

**APPEARANCE  
GRADE**

Cosmetic

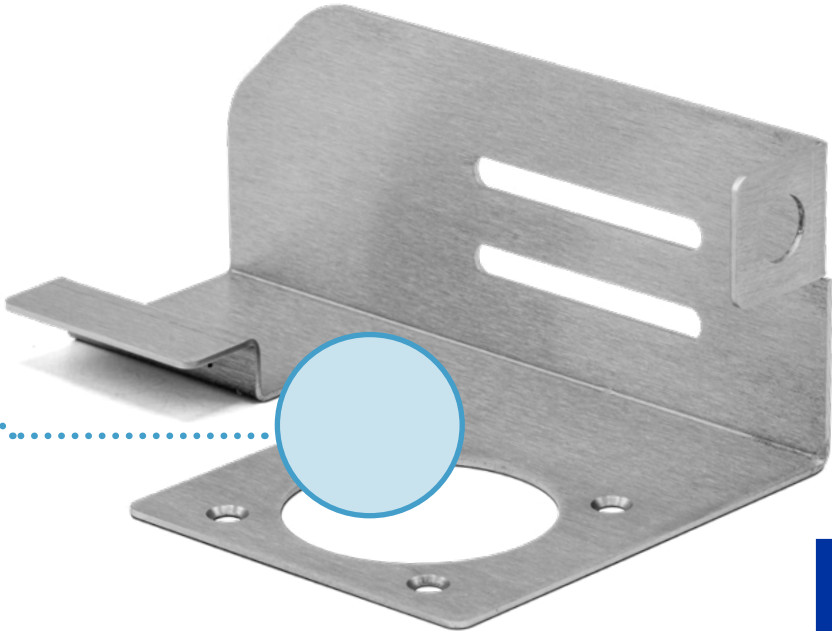
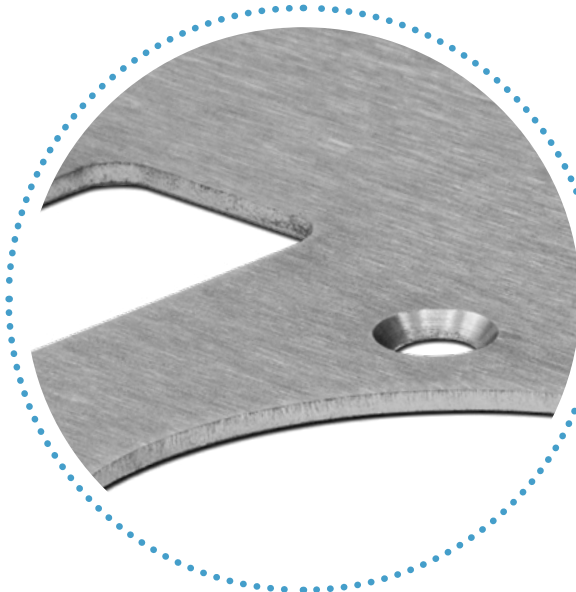

**FINISH**

Orbital

**APPEARANCE**

**GRADE**

Standard

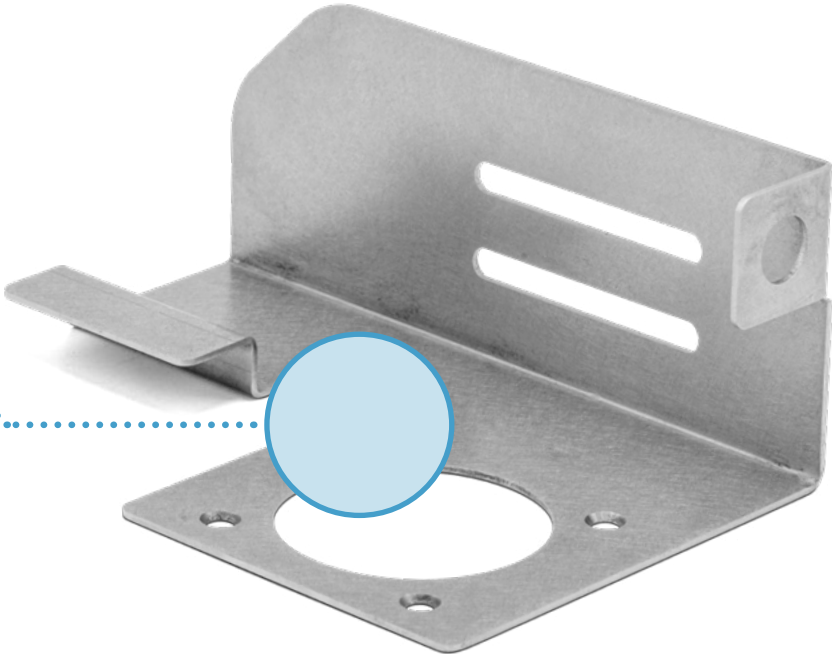
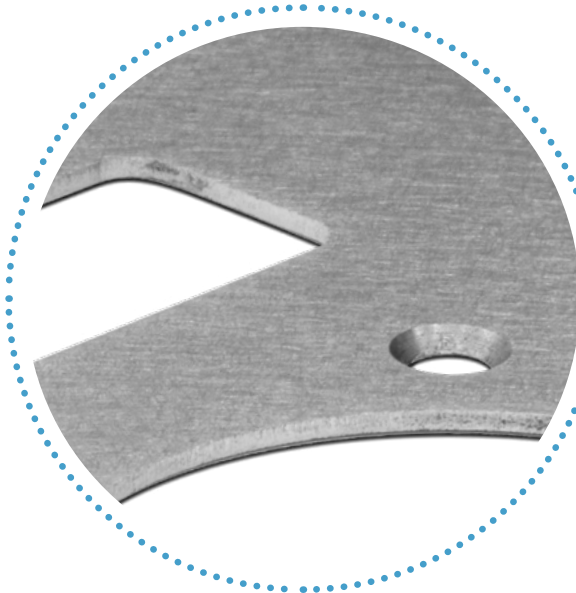

**FINISH**

Orbital

**APPEARANCE**

**GRADE**

Cosmetic

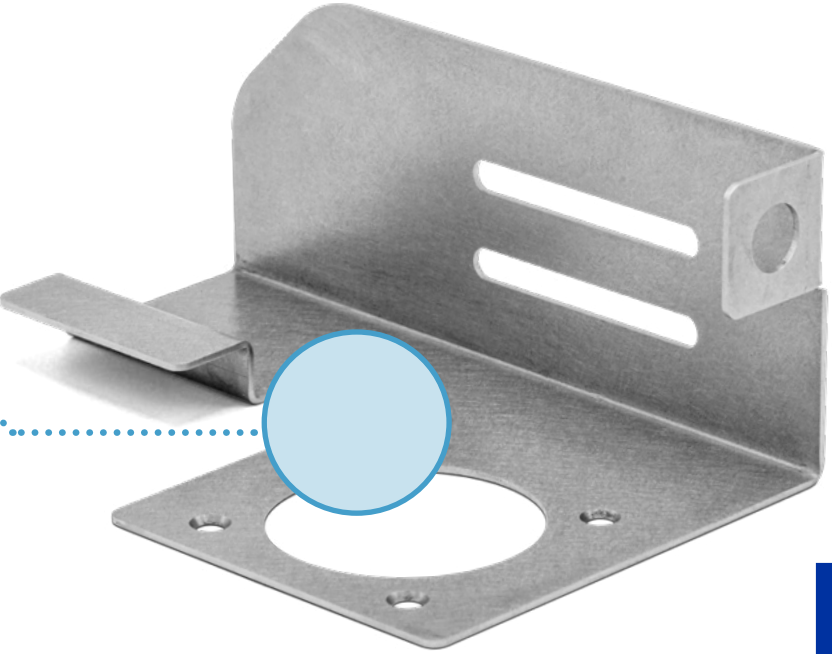
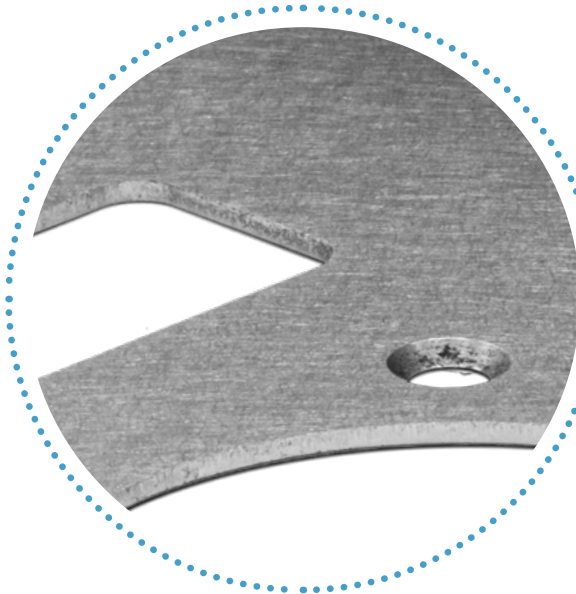

**FINISH**

Straight Grain

**APPEARANCE GRADE**

Standard

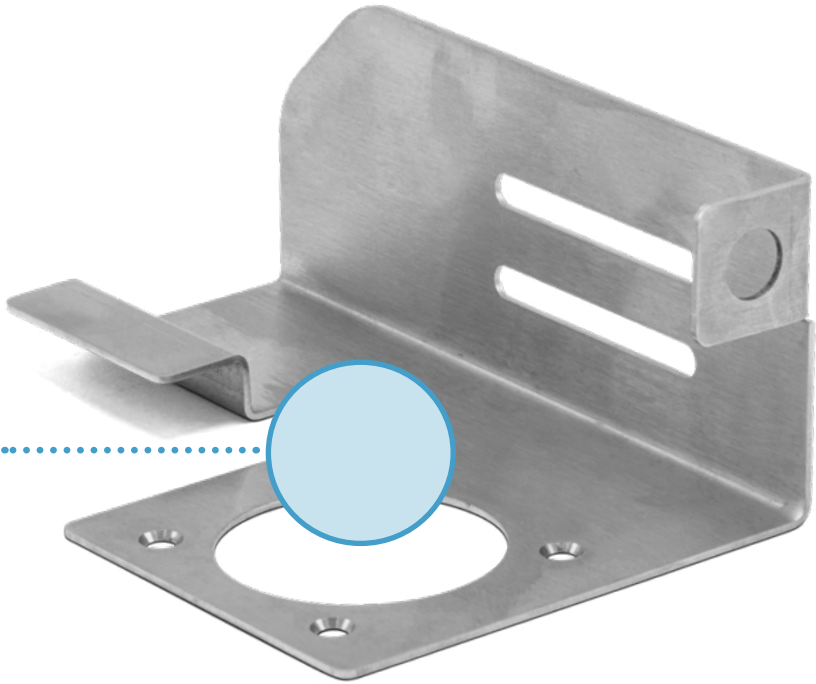
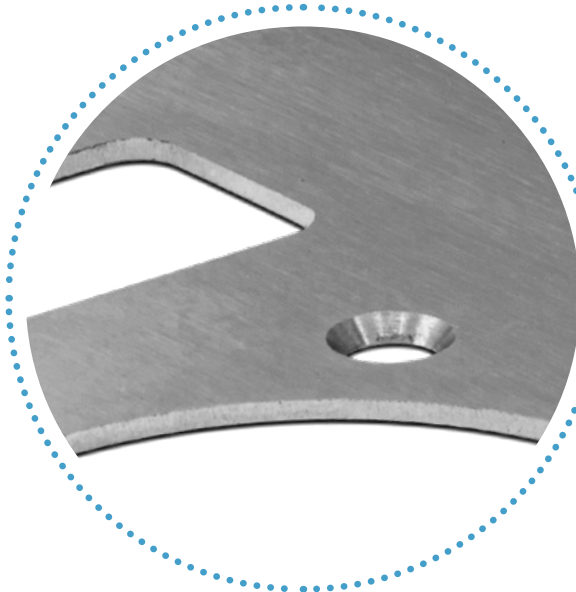

**FINISH**

Straight Grain

**APPEARANCE GRADE**

Cosmetic

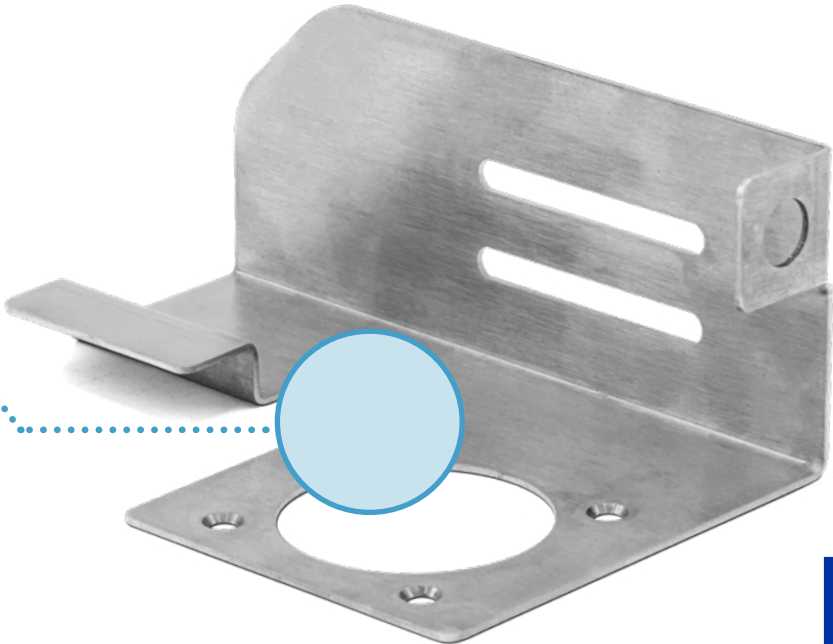
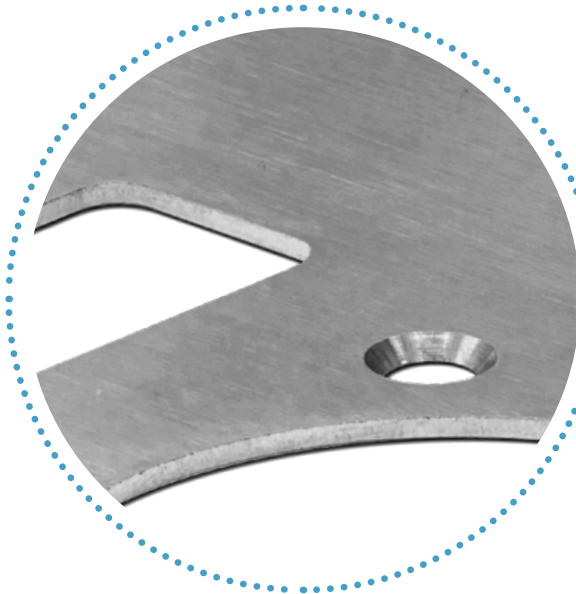

**FINISH**

Orbital

**APPEARANCE**

**GRADE**

Standard

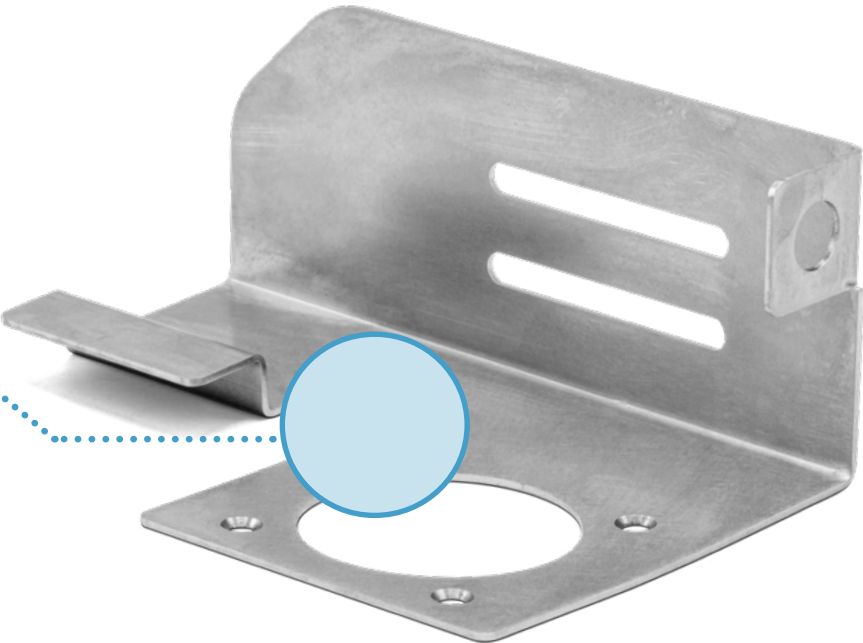
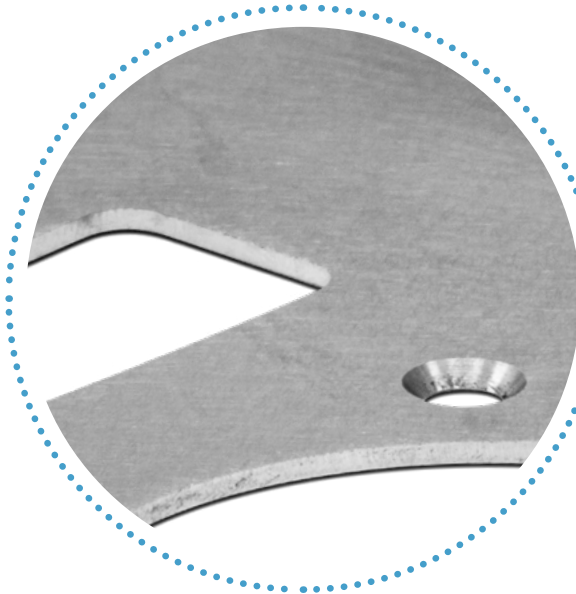

**FINISH**

Orbital

**APPEARANCE**

**GRADE**

Cosmetic

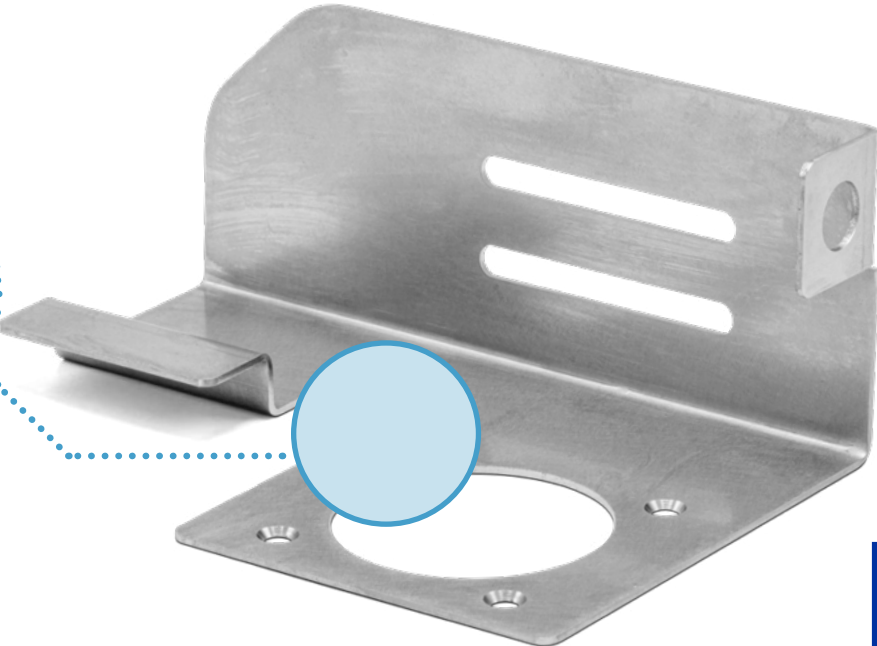
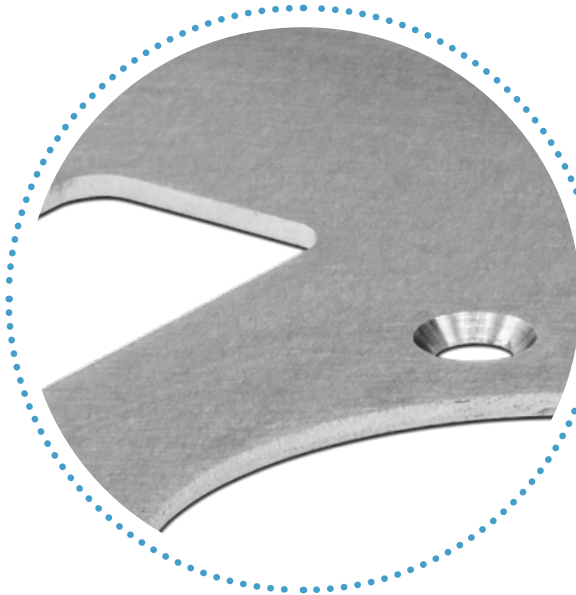



**FINISH**

Straight Grain

**APPEARANCE  
GRADE**

Standard

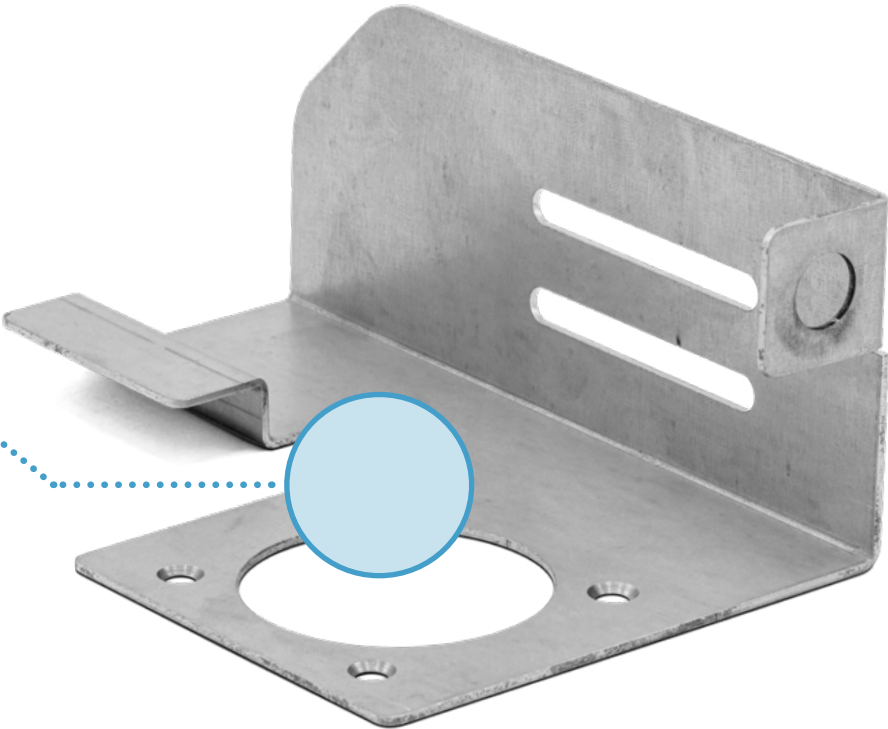
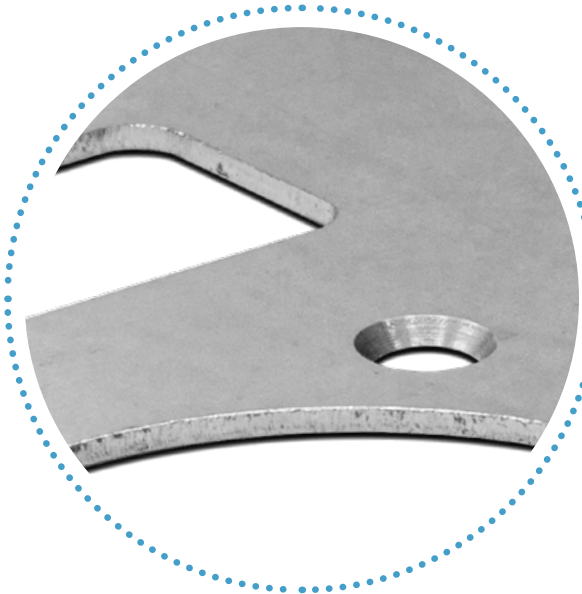

# Defect Acceptance

When choosing between Standard and Cosmetic appearance grades, we recommend reviewing the chart below for common appearance features and acceptable tolerances per defect.

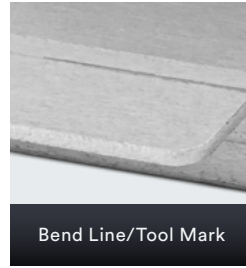

Bend Line/Tool Mark

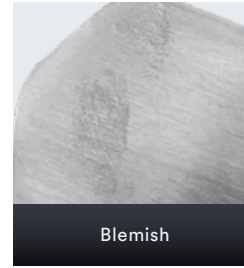

Blemish

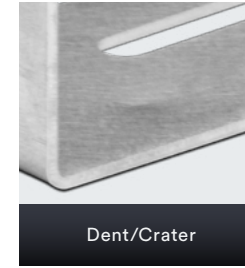

Dent/Crater



Scratch/Gouge

| Defect                                      | Description   | Standard              | Cosmetic                         |
|---|---|-----------------------|----------------------------------|
| Bend Line/Tooling Mark                      | Marks made in materials when a tool leaves an impact on the surface   | Accepted              | Accepted, Otherwise as Requested |
| Bleeding                                    | Uneven distortion in coloring of finish   | Moderate              | Moderate                         |
| Blemish (Smudge, Speck, Stain, Fingerprint) | A small mark or flaw on a face that does not breach the surface of the part   | Moderate              | Minimal                          |
| Burr  | A rough ridge or edge left at the intersection of two surfaces, typically caused by processing or damage            | Sharp Edge Test Pass  | Sharp Edge Test Pass             |
| Contamination                               | Unwanted foreign materials attached to the part   | None                  | None                             |
| Corrosion                                   | Oxidation or deterioration of the material  | None                  | None                             |
| Crack/Fracture                              | A separation of material on the surface of the part, typically caused by a high concentration of stress             | Moderate              | Moderate                         |
| Dent/Crater                                 | A surface depression  | 0.125 in. DIA         | None                             |
| Hanging Mark                                | An area free of finish due to hanging the part for finishing  | Minimal               | Minimal                          |
| Orange Peel                                 | Uneven or rough surface of a painted finish   | Minimal               | None                             |
| Overspray                                   | Excess paint that spreads beyond the desired coverage area  | Moderate              | Minimal                          |
| Scratch/Gouge                               | A disruption in the surface caused by handling, damage, or processing that results in elongated grooves or cavities | 3 in. x 0.08 in. Ball | 3 in. x 0.04 in. Ball            |
| Warping/Oil Can                             | Unwanted change in flatness of the part, typically due to excessive heat or stress                                  | Moderate              | Moderate                         |



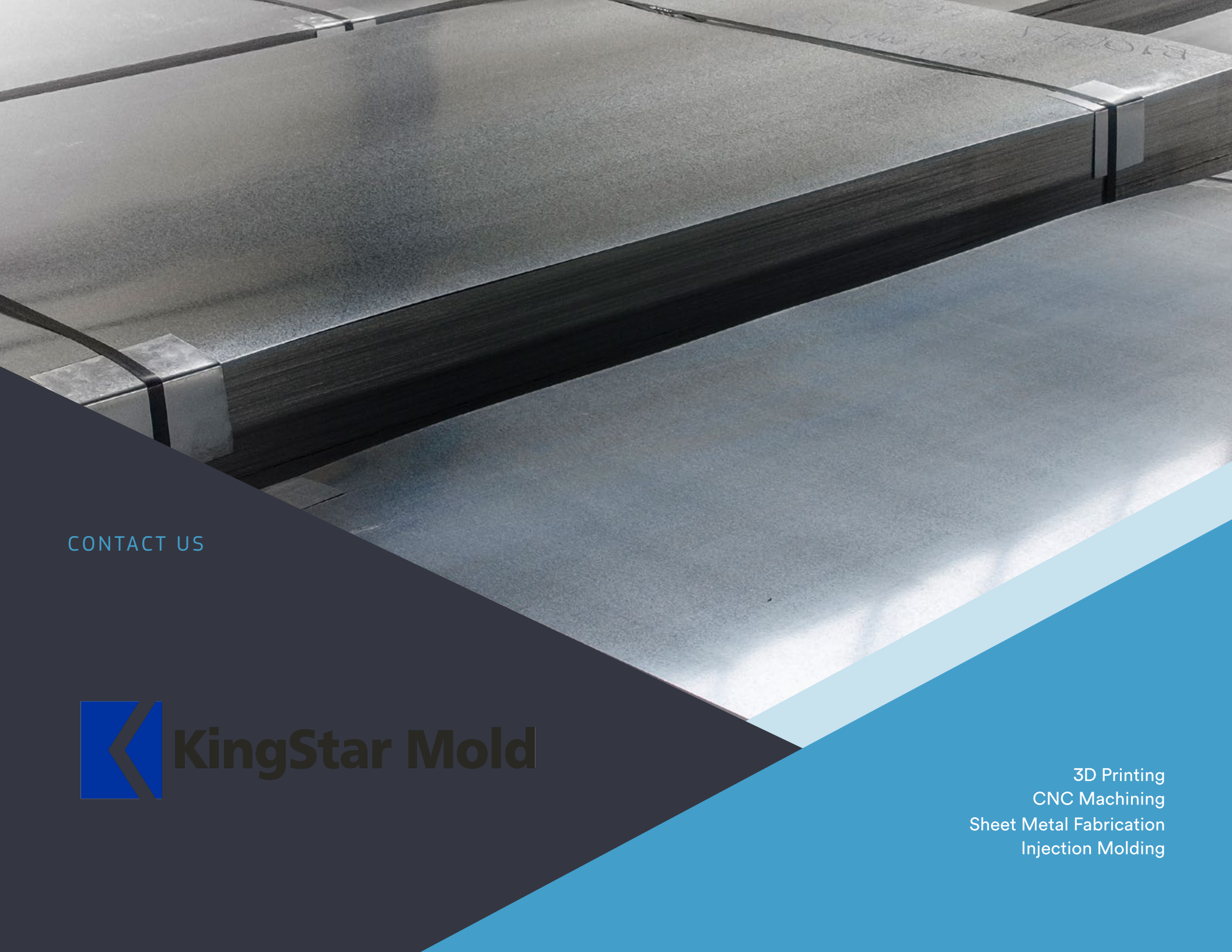

CONTACT US



**KingStar Mold**

3D Printing  
CNC Machining  
Sheet Metal Fabrication  
Injection Molding